

SALES DRAWING SALES DRAWING

SALES DRAWING SALES DRAWING

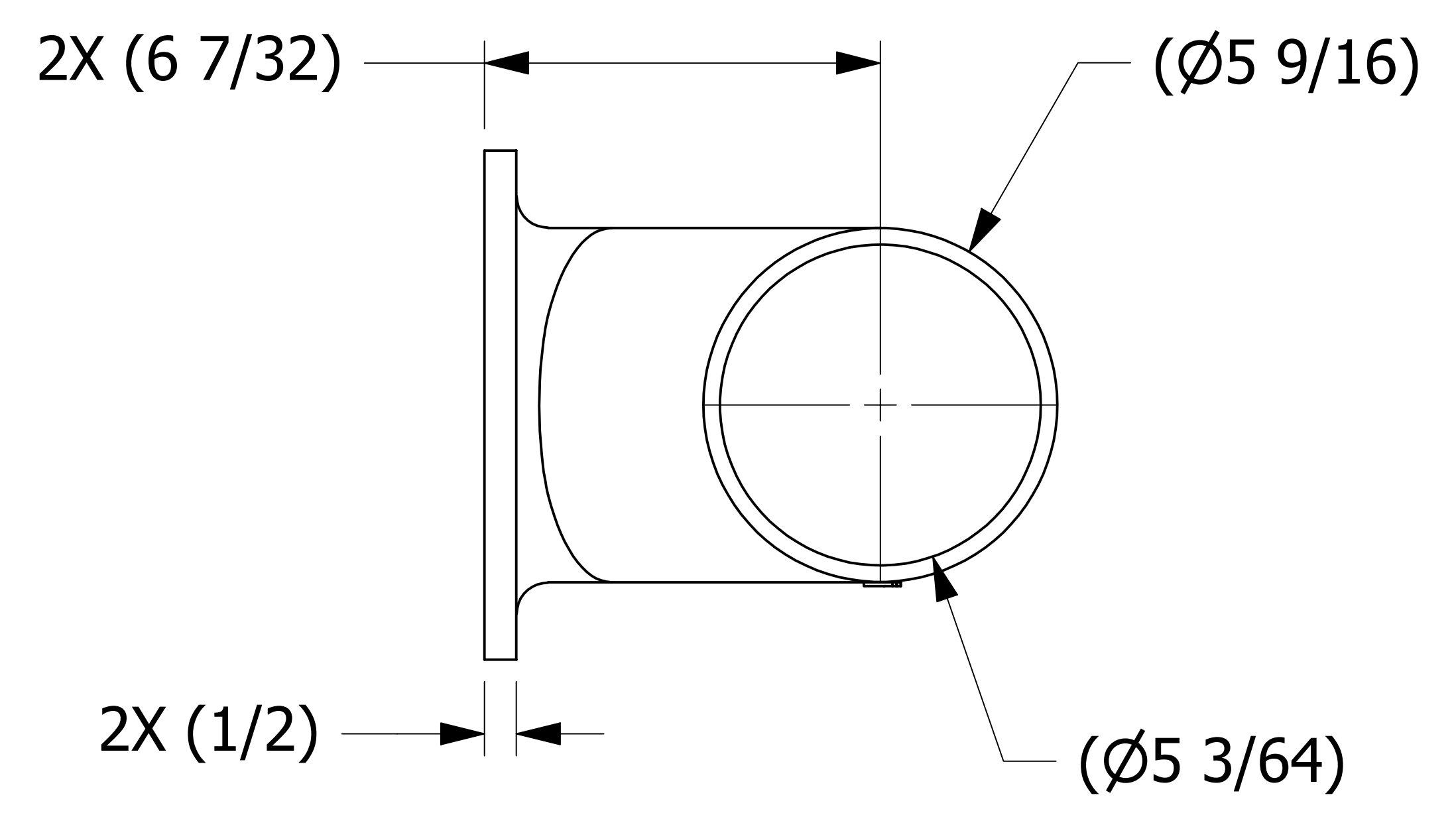
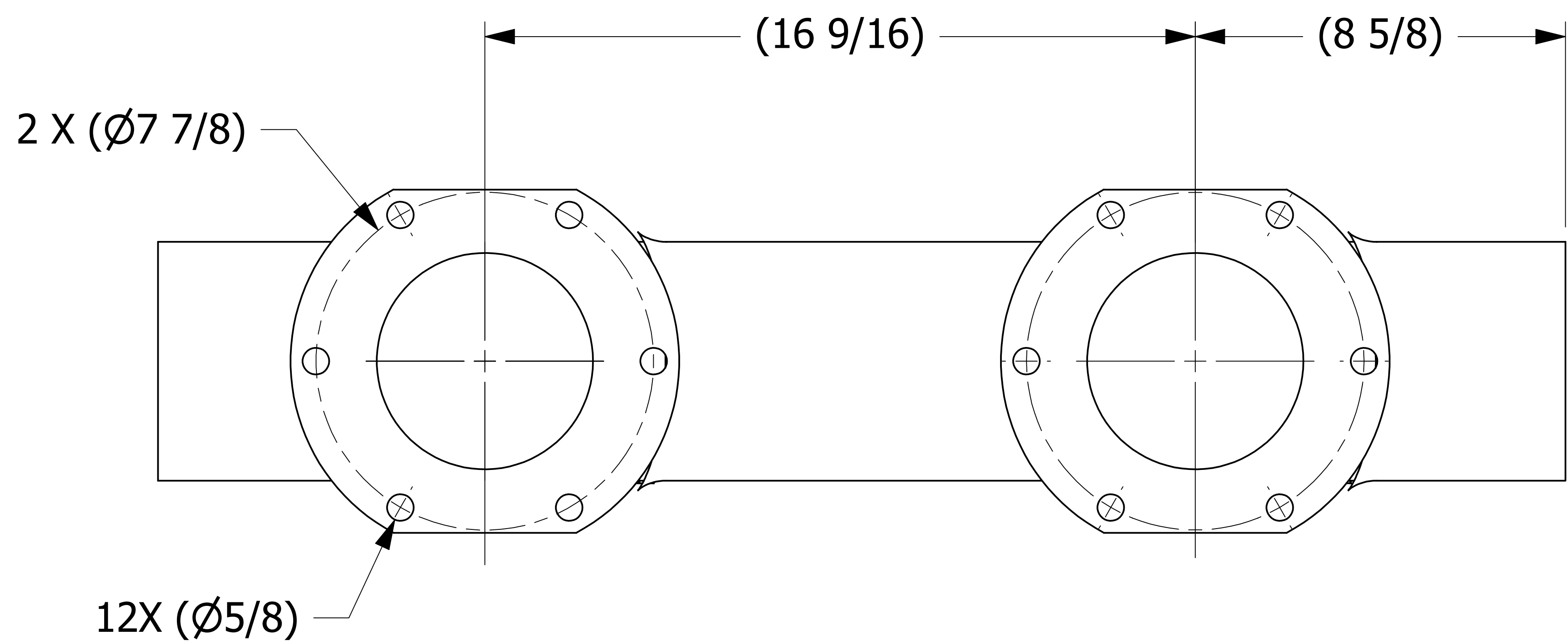

B	TAJ	2/22/11	REVISED DIMENSIONS AND NOTE
A	PJG	7/25/07	ADDED NOTE
REV	BY	DATE	DESCRIPTION

UNLESS OTHERWISE SPECIFIED DIMENSIONAL TOLERANCES FRACTIONAL: $\pm 1/16$ X.XX: $\pm .03$ X.XXX: $\pm .015$ ANGULAR: $\pm 1^\circ$ DEBURR ALL SHARP EDGES. ALL MACHINED SURFACES TO HAVE A 125 RMS FINISH UNLESS NOTED OTHERWISE.	DRAWN BY: CHL
THIRD ANGLE PROJECTION	CHECKED BY: VD
	PROTOTYPE BY: CHL
	PROTOTYPE DATE:
	APPROVED FOR PRODUCTION BY: ACC
	PRODUCTION DATE: 8/26/2004

<b>SALCO PRODUCTS, INC.</b>		
PART NAME: <b>DOUBLE LATERAL 5"</b>		
MATERIAL: <b>SEE BOM</b>		
PROJECT #: <b>110211</b>	SHEET #: <b>1 OF 1</b>	SCALE: <b>1:2</b>
DRAWING #: <b>E19420</b>	PART #: <b>PD5ADD02</b>	

THIS PRINT, PROPERTY OF SALCO PRODUCTS INC. CONTAINS PROPRIETARY INFORMATION AND MUST NOT BE COPIED, REPRODUCED, OR USED DETRIMENTALLY TO OUR INTEREST.